



E-PLANT® TRIPLE DECK

The revolutionary E-Plant is the industry's only true high production triple-deck screening/crushing system on one chassis—transportable in one pull—for the aggregate, asphalt, and recycling industries.

PRIMARY FEATURES

- 1 Tows in one pull. Jeep available where required. Check with your DOT.
 - » Screen/cross conveyors are positioned to allow convenient use of radial stackers.
 - » Screen products first before crushing, crush all products or crush with the grizzly product removed.
- 2 Triple-deck screening/crushing system enables processing of up to five products (including three spec products) at one time.
 - » Reversible cross conveyor enables return of two decks back to increase production well beyond 40 percent, compared to our industry-leading UltraMax® 1200-25 CC, with no increase in wear and maintenance costs.
- 3 Optional, easy-on, easy-off electro-magnet assembly.
 - » Features the industry's first LIFETIME ROTOR WARRANTY on its solid-steel, three-bar, sculptured rotor—the industry's heaviest—to keep you up and crushing.*

* North America only.



ADDITIONAL FEATURES

- » Easily transports with hydraulic folding conveyors.
- » Drop-in grizzly deck options.
- » Includes removable electrical control panel featuring pre-wired receptacles for radial stackers.
- » Control panel has interlocked controls with breakers for motor protection.
- » Replaces Jaw/Cone/Screen multi-unit systems for a much lower initial investment while maintaining a high production of cubical spec product. Greatly reduces maintenance and fuel costs and is easily transported.
- » Manage the feeder speed for complete control of the flow of material into the impactor and on return conveyor with Variable Frequency Drives (VFD).
- » Includes wireless remote control for the feeder shutdown and all motor stop.



E-PLANT® TRIPLE DECK

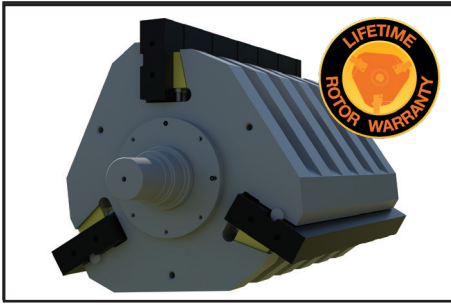

Solid-steel, three-bar, sculptured rotor with LIFETIME ROTOR WARRANTY, North America only.



Screen products first before crushing, crush all products or crush with the grizzly product removed.

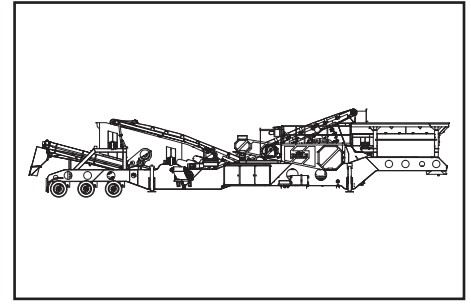

E-PLANT TRIPLE-DECK PORTABLE IMPACTOR PLANT TECHNICAL SPECIFICATIONS*

| Model | |
|--|--|
| Impactor | UM-25 |
| Operating Length | 75' 10" / 23.1M |
| Gross Weight | 126000lbs / 57150kg |
| Travel Length | 72' 6" / 22.1M |
| Travel Width | 11' 11" / 3.6M |
| Travel Height | 13' 6" / 4.1M |
| Feed Hopper Capacity | 17 yd ³ /23T / 13M ³ /20.9MT |
| Vibrating Feeder | 18' x 45.5" / 5.5M x 1.2M |
| Feeder Grizzly Deck | 5' long, two step / 1.5M long, two step |
| On-Plant Power Supply Diesel | 340HP diesel engine and 100kW generator |
| On-Plant Power Supply Electric | 250HP all-electric power |
| Crusher Discharge Conveyor Width | 42" / 1067mm |
| Triple Deck Inclined Screen | 5' x 16' / 1.5M x 4.9M |
| Top Screen Deck Cross Conveyor Width | 18" / 452mm |
| Middle Screen Deck Reversing Cross Conveyor Width | 18" / 452mm |
| Bottom Screen Deck Cross Conveyor (Hydraulic Fold) Width | 24" / 610mm |
| Under Screen Conveyor Width | 42" / 1067mm |
| Return Conveyor (Hydraulic Fold) Width | 24" / 610mm |

ULTRAMAX® IMPACTOR MODEL AND SPECIFICATIONS*

| Model | Diameter x Width | Width x Height | Power Required (HP / kW) | Approx. Weight (lbs / kg) | Rotor Weight (lbs / kg) | Production Capacity** |
|-------|---------------------------------|--|-----------------------------|------------------------------|----------------------------|------------------------|
| | Rotor (Inches / Millimeters) | Feed Opening (Inches / Millimeters) | | | | |
| UM-25 | 47 x 47 / 1194 x 1194 | 48 x 34 / 1219 x 864 | 150 - 300 / 112 - 224 | 32500 / 14773 | 13000 / 5897 | Varies by application. |

*Design specifications subject to change without notice.

**Contact your Eagle Sales Representative with your specific application for anticipated production capacity.

Call 800-25-EAGLE (800-253-2453) or visit www.EagleCrusher.com
525 South Market St., Galion, OH 44833 • 419-468-2288 • fax: 419-468-4840 • email: sales@eaglecrusher.com

Rev 02/2026

EAGLE CRUSHER®

©2026 Eagle Crusher Company, Inc.